

## **THE CUMULATIVE FATIGUE DAMAGE AND A FATIGUE LIFE PREDICTION OF THE LORRY FRAMES CARRYING ELEMENTS**

**Bohuš LEITNER**

*Bohuš Leitner, Assoc. Prof., PhD.*

*Faculty of Special Engineering, University of Žilina, Dep. of Technical Sciences and Informatics,  
ul.1.mája 32, 010 26 Žilina,  
SLOVAKIA*

**Abstract:** *The goal of this paper will be to present FEM application in the TATRA 815 lorry frame construction fatigue life estimation. Construction critical nodes from the fatigue damage point of view have been found and analyzed. Analysis of the particular traffic states influence on the fatigue damage cumulation is going to be presented too.*

**Key words :** *Cumulative damage prediction, Fatigue life, Fatigue damage cumulation, Dynamic analysis, Fatigue life prediction, Computer simulation*

### **INTRODUCTION**

The goal of this paper is to present the selected results of the computer simulation analysis of fatigue damage lorry frames. This simulation concentrates to the most important aspects which are typical for means of transport working conditions, using of the obtained computational models for a working exciting simulation of a real lorry structure, dynamic analysis of the vehicle critical parts stress under the influence of typical working conditions, the fatigue life prediction of the analyzed vehicle most exposed parts.

During the computational simulation of the chosen vehicle (TATRA 815 S2 – Fig.1) under the modelled conditions of its service, it was necessary to consider that it is a kind of vehicle whose traffic conditions are determined mainly by the influence of the following aspects: roadways and terrain surface unevenness and traffic velocity.

### **CHARACTERISTIC OF ANALYSING PARTS OF VEHICLE**

It is well known from the technical publications and from the similar performed analyses of the various transportation vehicles kinds, that the most loaded lorry parts are their

bearing members (bearing frames, subsidiary bearing constructions) and axles. They carry the loads occurred at the interaction of the vehicle instantaneous weight influence and roadways surface undulation influence in synergy with chosen traffic velocity.

This is the reason why the presented description is oriented mainly to these structure entities. Vehicle TATRA 815 S2 as lorry undercarriage consists of a frame, a subsidiary frame (Fig.2), front and back hangers composed of axels with wheels, cushioning, own brakes and an axle control operating machinery, a control and a brakes machinery.



**Fig.1 The Lorry Tatra 815 S2**

The main vehicle bearing part is formed by a spinal frame, to which a subsidiary ladder frame for bodywork assessment, a driving-gear and a sleigh is mounted. The spinal frame consists of particular axle gear-boxes, an additional gear-box, front and back joining piece, front and back bearing tube and transoms. Connecting of the mentioned parts is realized by using of flanges and bolted connections.

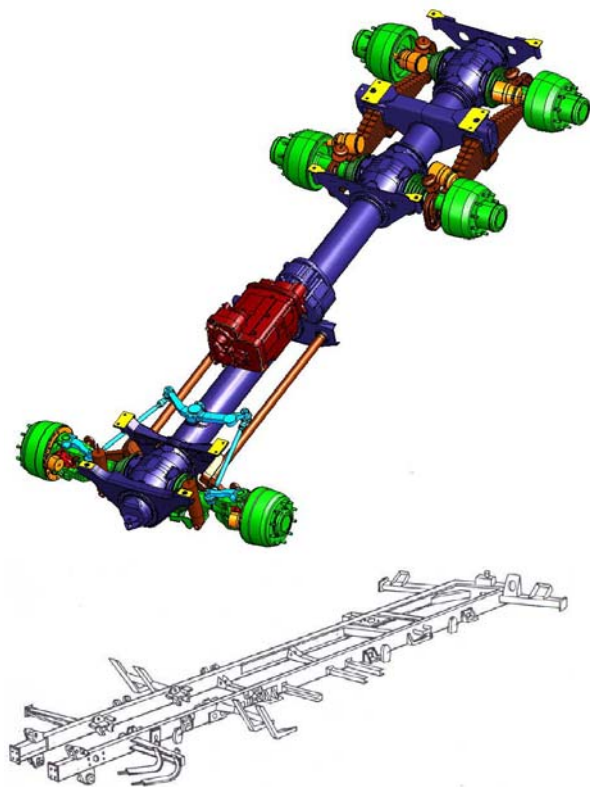

**Fig.2 Three-dimensional model of TATRA 815 S2 lorry undercarriage and subsidiary ladder frame**

The subsidiary ladder frame welded from longitudinal “U” shapes is mounted on the transoms by bolted connections. The “U” shapes are going through all the vehicle length and are interconnected by transoms. A cab, an engine together with a clutch, a sleigh, a reel, bumpers, draw-bar equipment etc. are mounted on transoms, brackets and holders of the subsidiary ladder frame.

### COMPUTATIONAL MODEL OF THE ANALYSED VEHICLE

Computational FEM model of the TATRA 815 S1 vehicle was built-up in COSMOS/M program in cooperation with TATRA Kopřivnice Company. In general, its applied realization consisted of several consequential phases:

- geometry model generation,
- definition of elements, their cross-section constants and material characteristics,
- generation of final element mesh,
- definition of boundary conditions,
- setting of acting load,
- computing and verification of results.

Beam elements of the *Beam3D type*, mass elements of the *Mass type*, axial spring boundary elements of the *Bound type* together with damping units were used for generation of finite-element model of the analysed vehicle. Generated model of the vehicle is presented on the Fig. 3.

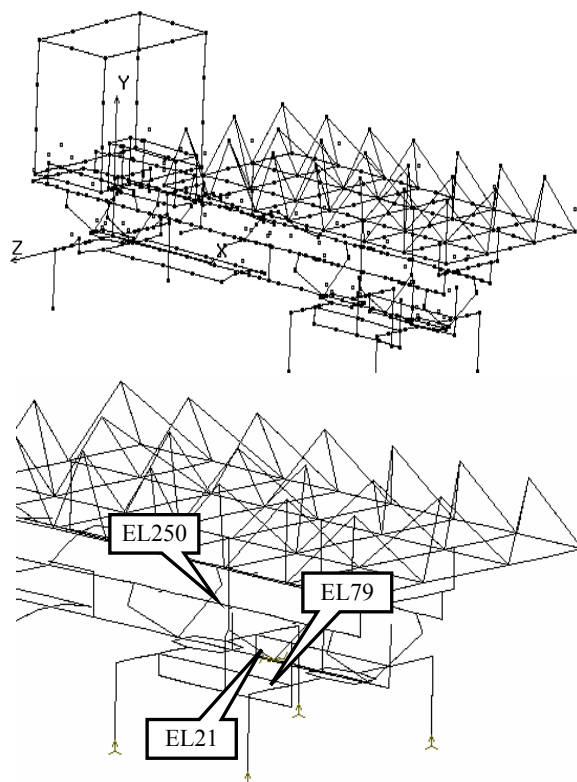

**Fig. 3 Finite-element model with definition of chosen vehicle critical parts location**

Elements No. 21, 79 and 250 are extremely stressed (Fig.3), as ensued from the graphical representation of performed strain analysis results and from the next performed analyses output files. Particular examined elements can be shortly characterized as follows

- **element 21** – part of the vehicle bearing spinal frame, specifically the back bearing tube, structural material – steel 11 523, shape according to Fig. 4a,
- **element 79** – part of the formed thick-walled bridge tube of the right central half-axle, structural material – steel 11 523, tube shape according to Fig. 4b,
- **element 250** – the longitudinal truss part of

the subsidiary bearing frame, approximately in the middle between both back axles, "U"

shape 250x100x7, structural material – steel 11 523, element shape according to Fig. 4c.

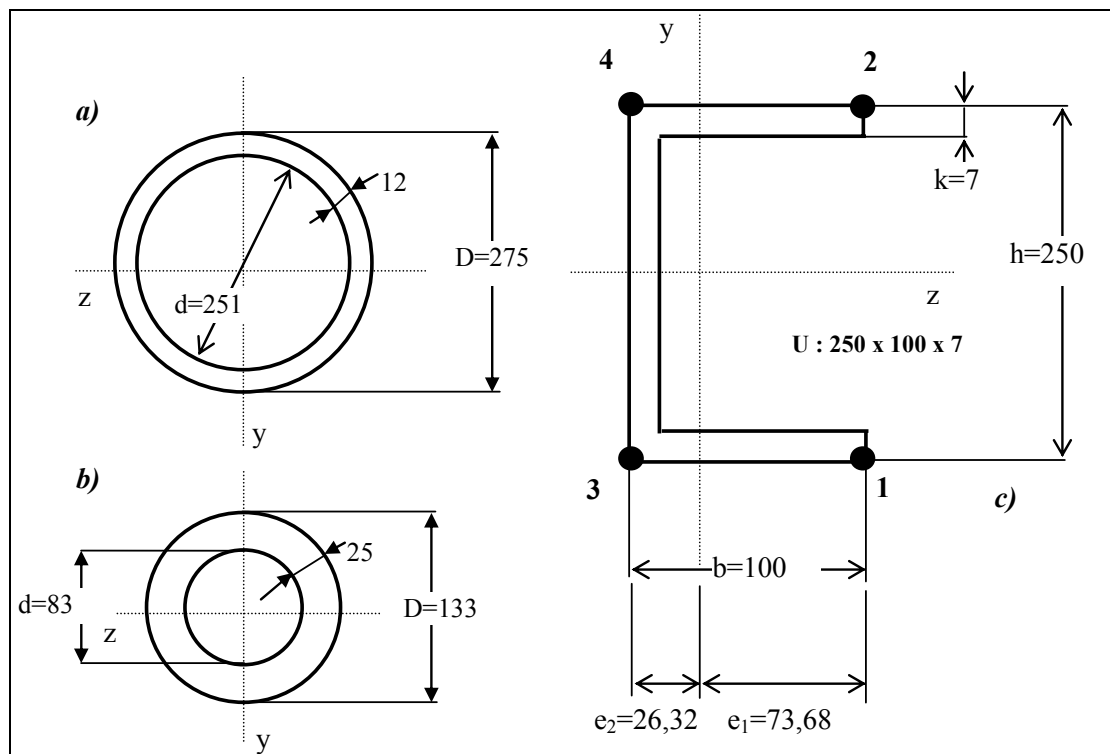

Fig. 4 Cross-sections of the analysed critical parts

Computational model of vehicle was excited by random function representing stochastic surface undulations of different quality roadways and relatively aggressive terrain conditions. Starting surface undulations of chosen (reference) roadway and terrain parts, identified on the base of valid roadway surface classifications were obtained by experimental measurements.

Performed experiments always resulted into one realization of the stochastic vertical unevenness course of the different quality roadway surfaces. Because of the experimental measurements difficulty and necessity to use more realisations of the stochastic vertical undulations behaviours for each surface class, it was more effective to use for the stochastic undulations behaviour mathematic modelling the application of Monte Carlo method [3]. On the base of the mentioned mathematical mechanism, the needed amount of the stochastic undulation function realizations for chosen segments was generated. These function realisations properly described roadways and terrain surface undulations, where the examined vehicle moved by the appropriate prescribed velocity.

## THE COMPUTATIONAL ESTIMATION OF A LORRY FRAMES FATIGUE LIFE

It is well known that vehicle reliability in operation, in particular its no-failure operation and lifetime is a dominant property for the vehicles as the typical representative of the dynamically stressed complex mechanical constructions. These properties gain importance continually. Obviously it relate to the transport velocity raising, the construction parts weight reduction, the computational safety constants decreasing, the new construction materials development and application, etc. Various vehicles operational failure cause analyses definitely prove that the fatigue process as the dynamic stress consequence assists in nearly all cases.

During the simulation, the dynamical analysis often ends at the modal-spectral construction properties determination, or at its stochastic oscillation solving only from the rigid body oscillation point of view, as for example vehicle vibration, swinging, rolling etc.

If the potential response acquisition is needed too, the problems related to problem size can often occur. This means enormous requirements

for the computer performance and the available operating memory size.

Fatigue life “computation” or rather “estimation” in fact differs from the value achieved during the real machine operation. This is caused mainly by the problems related to exact determination of external load characteristic parameters, which affect the construction during operation.

Fatigue strength values are not available for the specific construction nodes but mainly only for the material samples representing the perfect status, which occurs in the real operation conditions only rarely.

Considerations about the problem solution possibilities of the fatigue life estimation can be simply reduced to the four basic tasks [1]:

- selection of the construction critical locations, that will become the subject of the additional analysis,
- stress determination in the chosen critical locations and its “post-processing” using the methods suitable for the lifetime estimation,
- design or examination of the used construction material properties on the base of the chosen material characteristics,
- selection of the suitable computational procedure – theorem of the fatigue damage cumulation – which effectively join the material characteristics to the operational stress characteristics.

Application result of the suitable fatigue damage cumulation theorem is the lifetime estimation quantified value of the analysed critical part of the examined structure.

Rajcher’s theorem was used for the fatigue damage computations in the identified critical parts of the TATRA vehicle. This theorem defines the fatigue damage in the critical location of the construction part induced per one second and is expressed by the following equation [2]

$$D_s = \frac{\Gamma \cdot \left(\frac{w}{2} + 1\right) \cdot \left[ 2 \cdot \int_0^{\infty} f^{\frac{2}{w}} \cdot S(f) df \right]^{\frac{w}{2}}}{N_c \cdot \sigma_c^w}, \quad (1)$$

where  $w$  is exponent of S/N curve,  $\sigma_c$  is fatigue limit,  $N_c$  is limit number of cycles to failure,  $f$  is frequency,  $S(f)$  is spectral power density of the stress loading process,  $\Gamma \cdot \left(\frac{w}{2} + 1\right)$  is gamma function value. Time until the next failure can be expressed (in hours) as follows

$$T = \frac{1}{3600 \cdot D_s} = \frac{N_c \cdot \sigma_c^w}{3600 \cdot f_e \cdot \left(2 \cdot s_{\sigma}^2\right)^{\frac{w}{2}}} \cdot \Gamma \cdot \left(\frac{w}{2} + 1\right) \quad (2)$$

It is obvious that all the process can be realized only by means of the computer technique efficient enough. The approach in practice is that after import or calculation of the process spectral power density values the process standard deviation and process effective frequency of the probability density will be determined.

The practical application of the presented process was realized by the program created in the MATLAB environment. The worked computational program FATIGUE.M was used at the fatigue life computational estimation of the construction in the selected critical locations under the chosen characteristics of the lorry operating conditions. In the application the following material parameters defining the fatigue properties were used:

- slope of S/N curve  $w$ ,
- fatigue limit  $\sigma_c$ ,
- limit number of cycle  $N_c$ ,
- yield limit  $R_e$ ;

which gain the following values for the particular elements

- **EL 21:**  $w = 5,8$ ,  $N_c = 3 \cdot 10^6$ ,  
 $\sigma_c = 190 \text{ MPa}$ ,  $R_e = 355 \text{ MPa}$ ;
- **EL 79:**  $w = 5,8$ ,  $N_c = 3 \cdot 10^6$ ,  
 $\sigma_c = 190 \text{ MPa}$ ,  $R_e = 355 \text{ MPa}$ ;
- **EL 250:**  $w = 5,8$ ,  $N_c = 3 \cdot 10^6$ ,  
 $\sigma_c = 190 \text{ MPa}$ ,  $R_e = 355 \text{ MPa}$ .

Value  $\sigma_c$  was during this process reduced according to the stress average value and also according to factors affecting the fatigue limit (shape, size, stress concentration in the score, treatment quality etc.) [4].

From the influence analysis of the chosen operational condition characteristics it was determined, that the impact of the roadway surfaces from the 1<sup>st</sup> to 4<sup>th</sup> class on the TATRA vehicle parts fatigue damage level is nearly negligible. Therefore only a simulated loading process generated only from the stress behaviour originating during the vehicle operation on the 5<sup>th</sup> class roadways and in the terrain was further applied.

On the base of the statistically determined percentage expression of the analysed vehicle operation particular mode appearance (Table 1), the TATRA critical vehicle parts operation stress processes were created as the implication of the operation loads effect evoked by the analysed lorry operation on the 5<sup>th</sup> class roadways and in the terrain.

**Table 1 Percentage ratio estimation of the selected vehicle operation modes occurrence**

	5. class				terrain			
Velocity [km/h]	20	40	60	80	10	20	30	40
Estimation ratio [%]	10	10	10	10	15	20	15	10

Obtained stresses behavior in the particular critical elements of the TATRA vehicle construction were constituted by the 40.000 discrete values representing roadway or terrain distance with overall length 10 km.

The selected power spectral stress density behavior in the analyzed elements under the chosen velocity and specific roadway class are for the illustration displayed on the Fig. 5. These stress PSD behaviour in all the three determined critical construction locations were used as inputs for the worked *Fatigue.m* program.

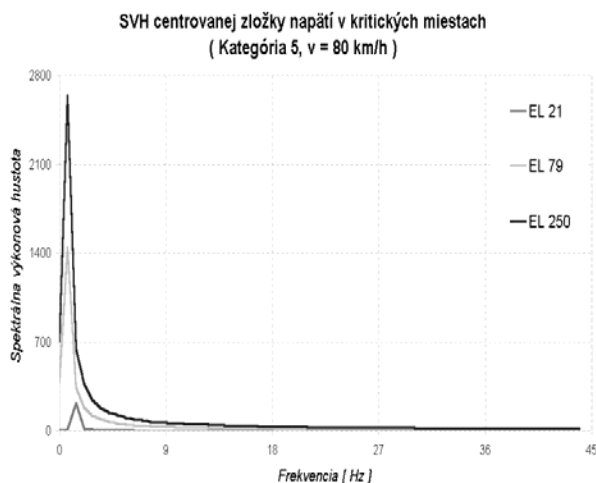

**Fig. 5 Stress PSD in the critical elements at the selected surface quality and velocity**

The critical vehicle parts lifetime estimations were its output. The obtained fatigue life estimations of the particular critical elements are listed in Tab. 2.

**Table 2 Estimated fatigue life values of the vehicle critical parts during its real operating conditions**

Element	EL 21	EL 79	EL 250a	EL 250b	EL 250c	EL 250d
lifetime estimation [in hours]	27 251	19 095	10 743	11 961	595 720	66 133

On the base of performed analyses and comparisons, it is possible to state that in term of the selected operation condition characteristics influence evaluation on the transport vehicle construction parts dynamic stress level, both examined transport vehicle operation condition characteristics (roadway and terrain unevenness and operational velocity) have significant influence on the vehicle critical parts stress.

It is obvious that it was not possible to analyse all the actuating characteristics and factors of the typical lorry operating conditions.

Therefore it is necessary to understand the proposed paper as the contribution to the solution of the problem related mainly to the operational processes modelling and computer simulation.

## CONCLUSION

From the realized calculations, it is possible to state that the analysed TATRA lorry construction is sufficiently dimensioned from the fatigue damage point of view. The goal of the paper was mainly to

- present the methodology of the fatigue life prediction based on the modelling of the working conditions most important factors,
- show the possibilities of the available software optimal use based on the FEM in order to obtain the results needed to the fatigue life prediction,
- verify the suggested computational approach on the specified lorry structure.

## REFERENCES

- [1] Melcher, R.: Structural Reliability Analysis and Prediction. Sec.edition. John Wiley & Sons, 1999.
- [2] Růžička, M.: Kritéria a postupy při posuzování únavové pevnosti a životnosti konstrukcí, ČVUT, Praha 1999. On web: [http://mechanika.fs.cvut.cz/sources\\_old/pzk/obsah.html](http://mechanika.fs.cvut.cz/sources_old/pzk/obsah.html)).
- [3] Leitner, B.: Modelling and Simulation of Transport Machines Working Conditions by using of Autoregressive Models. In:

Academic Journal “Mechanics, Transport, Communications“, Issue 1/2007, Article No. 0079, VTU Todora Kableškova, Sofia, Bulgaria, 10 pp. Wwww: < <http://mtc-aj.com/php/welcome.php?lang=gb> >.

- [4] Leitner, B.: Risk Factors in Process of Fatigue Life and Safety Estimation of Technical Systems. In: Zbornik radova - Nacionalna konferencija :Upravljanje vanrednim situacijama”, Univerzitet u Nišu, Fakultet Zaštite Na Radu u Nišu, Niš, Serbia

2007, p. 179-186

**The work has been supported by the grant project VEGA No.1/3154/06 named “The influence of stochastic dynamic loads of transport machines for fatigue life and reliability of theirs structure elements”.**

**Reviewer:** prof. Ing. Alexej CHOVANEC, PhD.

## **ВРЕДАТА ОТ НАТРУПВАЩАТА СЕ УМОРА И ПРЕДСКАЗВАНЕ НА ПРОДЪЛЖИТЕЛНОСТТА НА УМОРАТА ПРИ НОСЕЩИТЕ ЕЛЕМЕНТИ НА РАМАТА НА КАМИОНА**

**Бохуш ЛЕЙТНЕР**

*доц. д-р Бохуш Лейтнер.*

*Факултет за специално инженерство, Университет в Жилина, Катедра „Технически науки и информатика”, ул. 1 май 32, 010 26 Жилина,*

**СЛОВАКИЯ**

**Резюме:** *Целта на този доклад е да представи прилагането на метода на крайните елементи при преценката на продължителността на умората в конструкцията на рамата на камион TATRA 815. Намерени и анализирани са критичните възли на конструкцията от гледна точка вредата от умората. Представен е също така анализ на влиянието на конкретните състояния на движение върху натрупване на вредата от умора.*

**Ключови думи :** *предсказване на натрупващата се вреда, продължителност на умората, натрупване на вредата от умора, динамичен анализ, предсказване на продължителността на умората, компютърно симулиране.*